

METAL KOLOR

BOBINAS DE ESPIRAL DE METAL

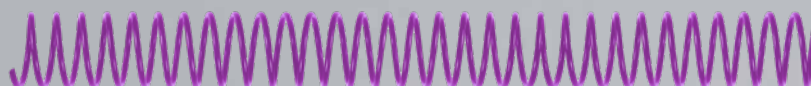

MK



COLORES DISPONIBLES

COLORES ESTÁNDAR

BLANCO



NEGRO



PLATA



COLORES PARCHÍS

AMARILLO



NARANJA



ROJO



AZUL

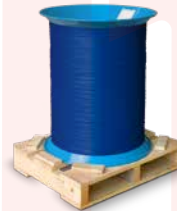

VERDE



COLORES PASTEL

ROSA PASTEL



TURQUESA PASTEL



LILA PASTEL



VERDE PASTEL



AZUL PASTEL



COLORES METALIZADOS

ORO BRILLANTE



BRONCE



PASOS DE PERFORACIÓN

El paso de perforación es la distancia entre el centro de un agujero y el centro del siguiente, y determina la cantidad y distribución de perforaciones a lo largo del borde del documento.

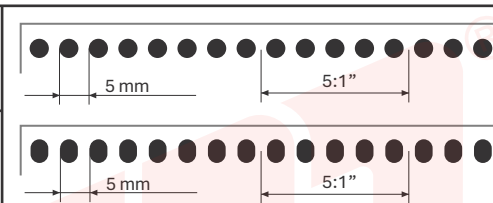
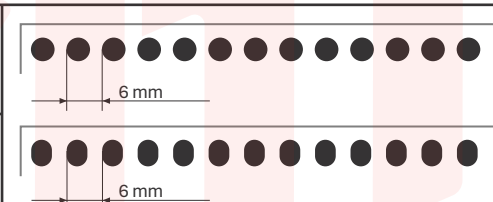
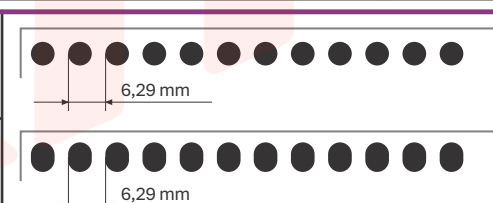
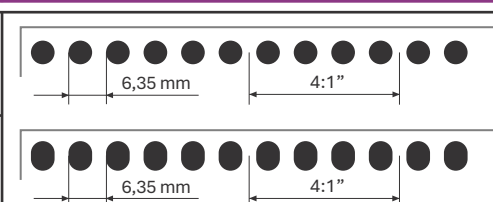
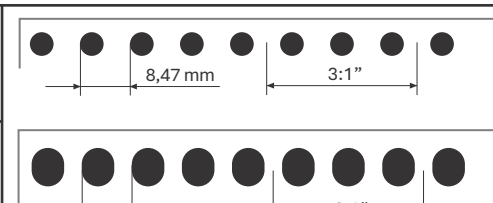







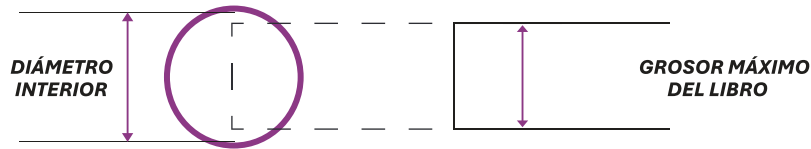

PASO	TALADROS		REPRESENTACIÓN GRÁFICA		
	NÚMERO	FORMA			
5,00 mm 5:1"	A5	41	REDONDO Ø 3,2 mm		EN DESUSO
	A4	59	-----		
	A3	83	OVALADO 3,2 x 4 mm		
6,00 mm	A5	34	REDONDO Ø 3,5 mm		EN DESUSO
	A4	49	-----		
	A3	69	OVALADO 3,2 x 4,5 mm		
6,29 mm 0,2475"	A5	33	REDONDO Ø 4 mm		RECOMENDADO
	A4	47	-----		
	A3	66	OVALADO 4 x 5 mm		
6,35 mm 4:1"	A5	32	REDONDO Ø 4 mm		COMÚN
	A4	46	-----		
	A3	65	OVALADO 4 x 5 mm		
8,47 mm 3:1"	A5	24	REDONDO Ø 4 mm		Ø GRANDES
	A4	34	-----		
	A3	49	OVALADO 5,5 x 6,5 mm		



Se recomienda el taladro ovalado sobre el redondo, ya que facilita la inserción de la espiral y el paso fluido de las páginas del cuaderno.

DIÁMETROS DE ESPIRAL

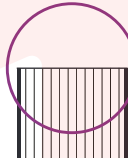
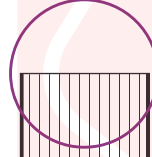
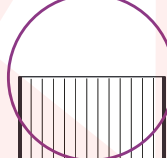
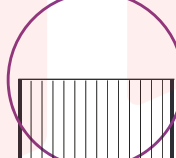
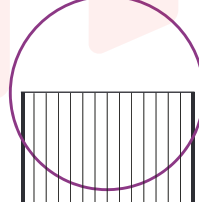

										
DIÁMETRO INTERIOR Ø	6 mm	8 mm	10 mm	12 mm	14 mm	16 mm	18 mm	20 mm	23 mm	25 mm
GROSOR MÁX. LIBRO	0,4 cm	0,6 cm	0,8 cm	1,1 cm	1,3 cm	1,4 cm	1,5 cm	1,6 cm	2,0 cm	2,2 cm
MÁXIMO DE HOJAS	35	55	75	95	115	135	150	170	200	220

					
DIÁMETRO INTERIOR Ø	28 mm	30 mm	32 mm	35 mm	38 mm
GROSOR MÁX. LIBRO	2,5 cm	2,7 cm	2,9 cm	3,2 cm	3,5 cm
MÁXIMO DE HOJAS	250	265	275	295	315

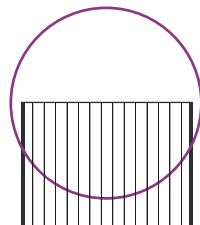
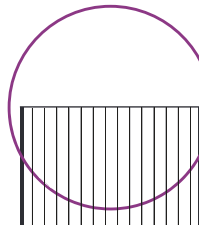
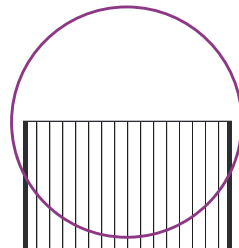
			
DIÁMETRO INTERIOR Ø	42 mm	45 mm	50 mm
GROSOR MÁX. LIBRO	3,7 cm	3,8 cm	4,4 cm
MÁXIMO DE HOJAS	350	370	420

LONGITUD DE ESPIRAL

Para calcular la longitud de la espiral, se toma la medida del lado del documento a encuadernar y se le añaden 3 cm adicionales (1,5 cm sobrantes en cada extremo de la espiral).

Longitud: mínima 17 cm - máxima 104 cm

A5 210 x 148,5 mm

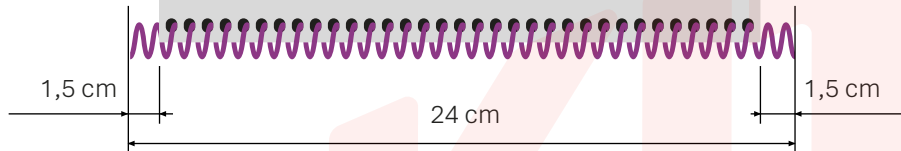

A4 297 x 210 mm



A3 420 x 297 mm

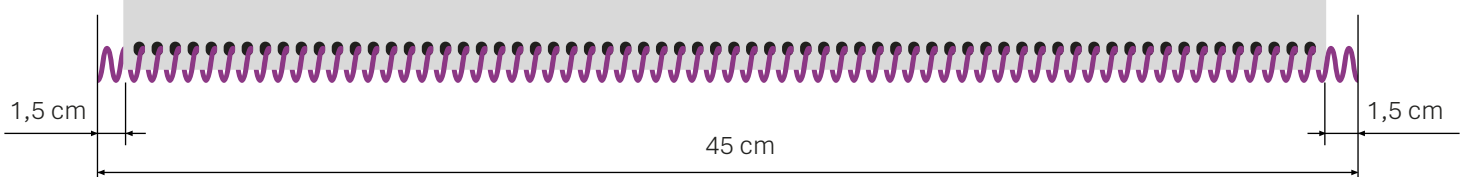

ESPECIFICACIONES TÉCNICAS

GROSOR DEL HILO (mm)	PESO
0,90	450 Kg
1,00	450 Kg
1,10	450 Kg
1,15	450 Kg
1,20	450 Kg
1,30	450 Kg
1,40	450 Kg
1,50	450 Kg





MKM

MKM Comercial S.L.

P.I. Talluntxe I, c/A, nave 8

31110 NOÁIN (Navarra)

Tel. 948249944 - mkm@mkm.es



www.mkm.es



BINDING EXPERTS SINCE 1987

GUÍA DE PASOS DE PERFORACIÓN

PASOS DE ESPIRAL

ESCALA 1:1,5	
LEYENDA	
	Cada 10 punzones
	Anular punzón
	No anular punzón
	Ajuste no necesario
	Puede necesitar ajustes
	Ajuste y corte necesarios

NÚMERO DE PUNZONES					
PASOS DE PERFORACIÓN	TAMAÑO / FORMA * DEL TALADRO		A5	A4	A3
5 mm (5:1")		3,2 x 4 mm	42	60	85
6 mm		3,5 x 4,5 mm	34	49	69
6,29 mm (0,2475")		4 x 5 mm	33	47	61
6,35 mm (4:1")		4 x 5 mm	32	46	65
		5,5 x 6,5 mm	24	34	49

297 x 420 mm

A3

FORMA DE PERFORADO

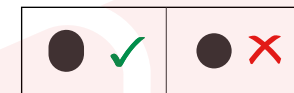

FORMA DEL HILO DE PVC

